

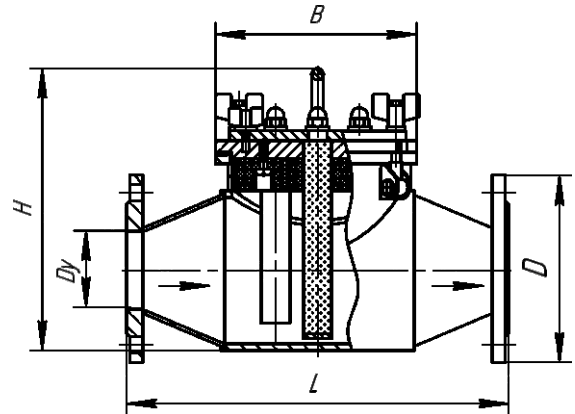

Rod Magnetic Separators Piped STS



Designed for refinement of dry and liquid materials from ferro magnetic impurities.

Installed on pipelines of product supply.

Applied in food industry for refinement of flour, sauces, mayonnaise, etc.

Name	Arbitrary pass, D_y , mm	Quantity of magnetic blocks, pcs	Dimensions, mm				Weight kg, not more
			L	D	H	B	
STS-50	50	4	350	160	260	150	12
STS-M-50							14
STS-65	65		400	180	270	184	16
STS-M-65							18
STS-M-80	80	5	450	195	300	192	20
STS-M-100	100		500	205		192	22

1. Magnetic induction on magnetic blocks' surface is not less than 0.5 T, according to technical specification.
2. Separator clean-up: type STS - manual; type STS-M - mechanical.
3. Operation pressure is not more than 0.8 MPa, operation temperature is not more than 60°C.
4. Manufacturing of separators accounting for customer's requirements is available.

