

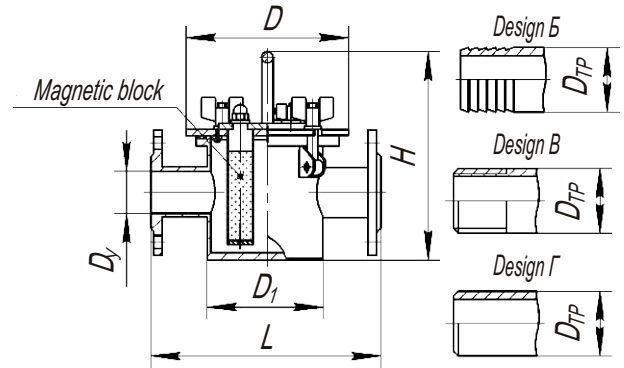

Rod Magnetic Separators Piped STM



Designed for refinement of liquid products from ferro magnetic impurities.

Installed on pipelines of product supply.

Applied in food industry for refinement of chocolate icing, syrup, molasses, etc.

Name	Arbitrary pass, D_y , mm	Q-ty of magnetic blocks, PCS	Dimensions, mm					Operation pressure, MPa, not more	Operation temperature, °C, not more	Weight, kg, not more						
			L	D	H	D_1	D_{TP}									
STM-M-25	25	3	240	156	165	107	34	0,8	150	6,3						
STM-25										5,7						
STM-M-32	32		260							42	48	57	76	7,2		
STM-32														6,7		
STM-M-40	40		280							89	108	136	160	8,2		
STM-40														7,6		
STM-M-50	50		5							320	186	230	158	76	9,2	
STM-50															8,6	
STM-M-65	65		7							350	190	240	170	89	108	14
STM-65																16
STM-80	80	9	450	360	336	268	136	160	18							
STM-100	100								22							
STM-125	125								32							
STM-150	150								32							

1. Magnetic induction on magnetic blocks' surface is not less than 0.5 T, according to technical specification.
2. Separator clean-up: manual - type STM; mechanical - type STM-M.
3. Manufacturing of separators accounting for customer's requirements is available.

